

No.3-27/EDN/DP/Accts/2007-2008/1213
U.T.Admn.of Daman & Diu,
Office of the Education Officer,
Dist. Panchayat, D & D, Diu.
Dated :- 18 / 02 /2008.

LIMITED TENDER NOTICE

Limited Tender are invited from your firm for supply of following item for the use of Educational Institutions of this Department as per the terms and conditions given below:

Sr.No.	Name of the Articles with Full details.	Quantity Required.	Cost per/ Nos. Items.
1.	Two Seated Desk & Bench (Teak wood), As per enclosed design.	160 No.	
2.	Class Room Tables (Teak wood). As per enclosed design.	26 No.	
3.	Moulded Plastic Chairs with arms.	55 No.	
4.	Cupboard (Steel) 78'x36x 18' with lock & sloving enamel paint with 20 gaze.	07 No.	
5.	Still racks 72x36x18 & sloving enamel paint with 20 gaze. (5 shelves).	06 No.	

TERMS AND CONDITIONS :-

1. Final and net rates, including Sales Tax, packing/forwarding charges etc. may be given. Rates will be valid for the period of 6 months from the date of receipt of Tender.
2. The amount will be paid on receipt of the articles as soon as bill is passed.
3. The goods will have to be supplied within **15 DAYS** from the date of receipt of Supply order at F.O.R., Diu i.e. Education Office, D.P., Diu.
4. The item which are not found satisfactory and inaccordance to the design, same will be returned and to be replaced at the supplier's own cost.
5. The Limited Tender should be submitted in sealed cover superscribing "LIMITED TENDER FOR SUPPLY OF FURNITURE ITEM" on **28-02-2008** at **3:00 p.m.** and will be opened on the same day at **4:00 pm.**
6. Bill should be submitted in duplicate, original one should be duly affixed with Revenue Stamp.
7. The dealer should be registered with the VAT Department.
8. The dealer should be dealing in tendered items.
9. The Tenderers shall fill in the tender properly and carefully.
10. The Tenderers shall not quote absurd rates or make corrections/over writings in the tender.
11. The amount/rates quoted by the Tenderers must be legible and clearly indicated.
12. Any tenders found containing any corrections/over writings shall be liable to be rejected as such.
13. Limited Tender will be available on the Web Site daman.nic.in.
14. All right to reject any or all Limited Tender is reserved with the Undersigned.

(B. B. MAKWANA)
EDUCATION OFFICER,
DIST. PANCHAYAT, D & D, DIU.

To,
The _____

(TEAK WOOD)

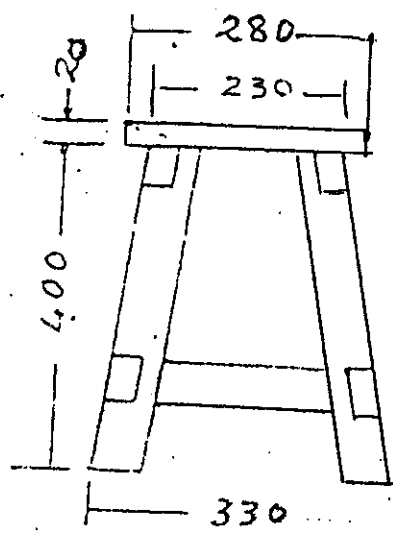
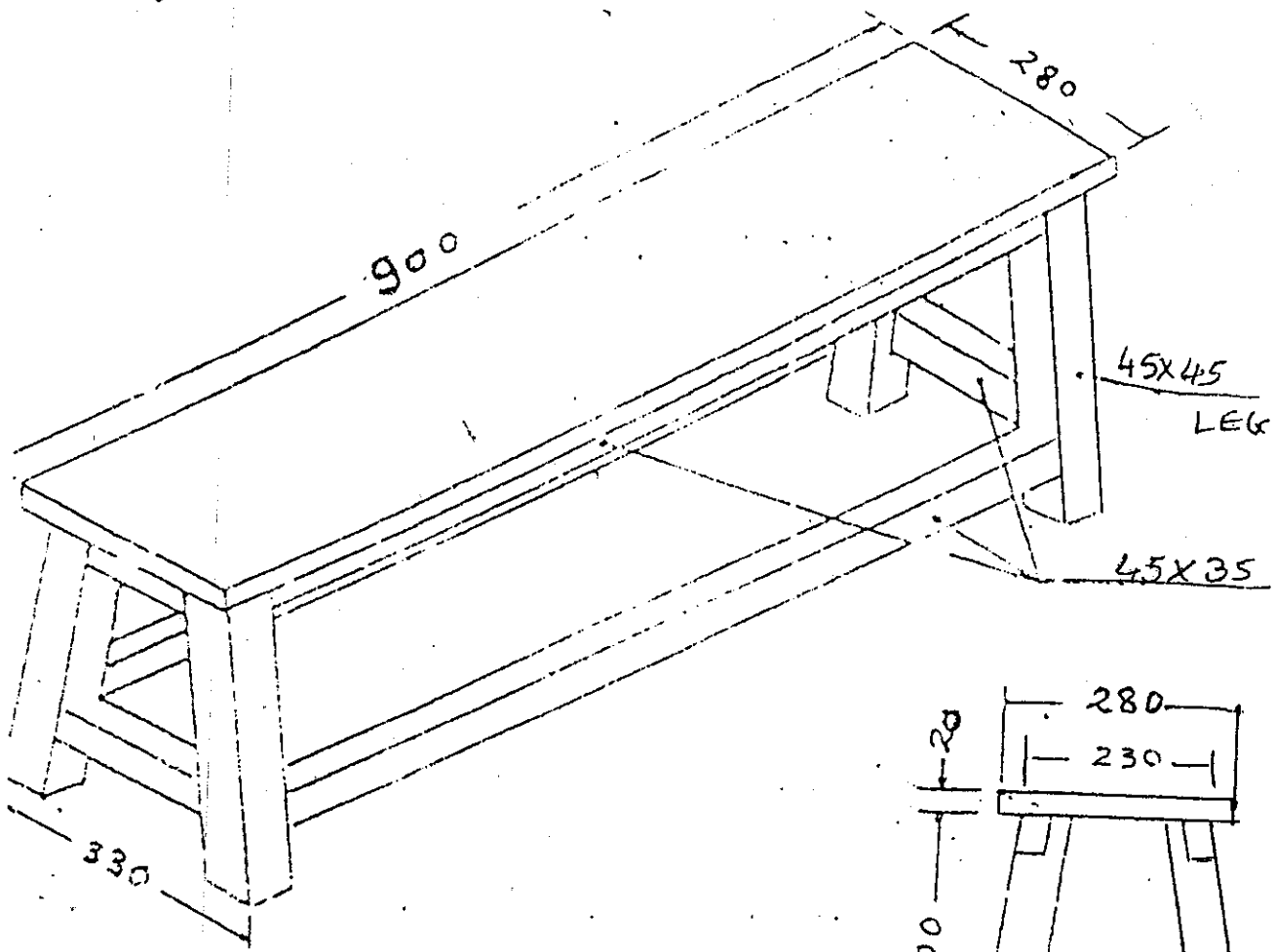

Measurement is shown in mm

[Signature]
District Panchayat D&D
DIU.

SS ROOM TABLE FOR TEACHERS

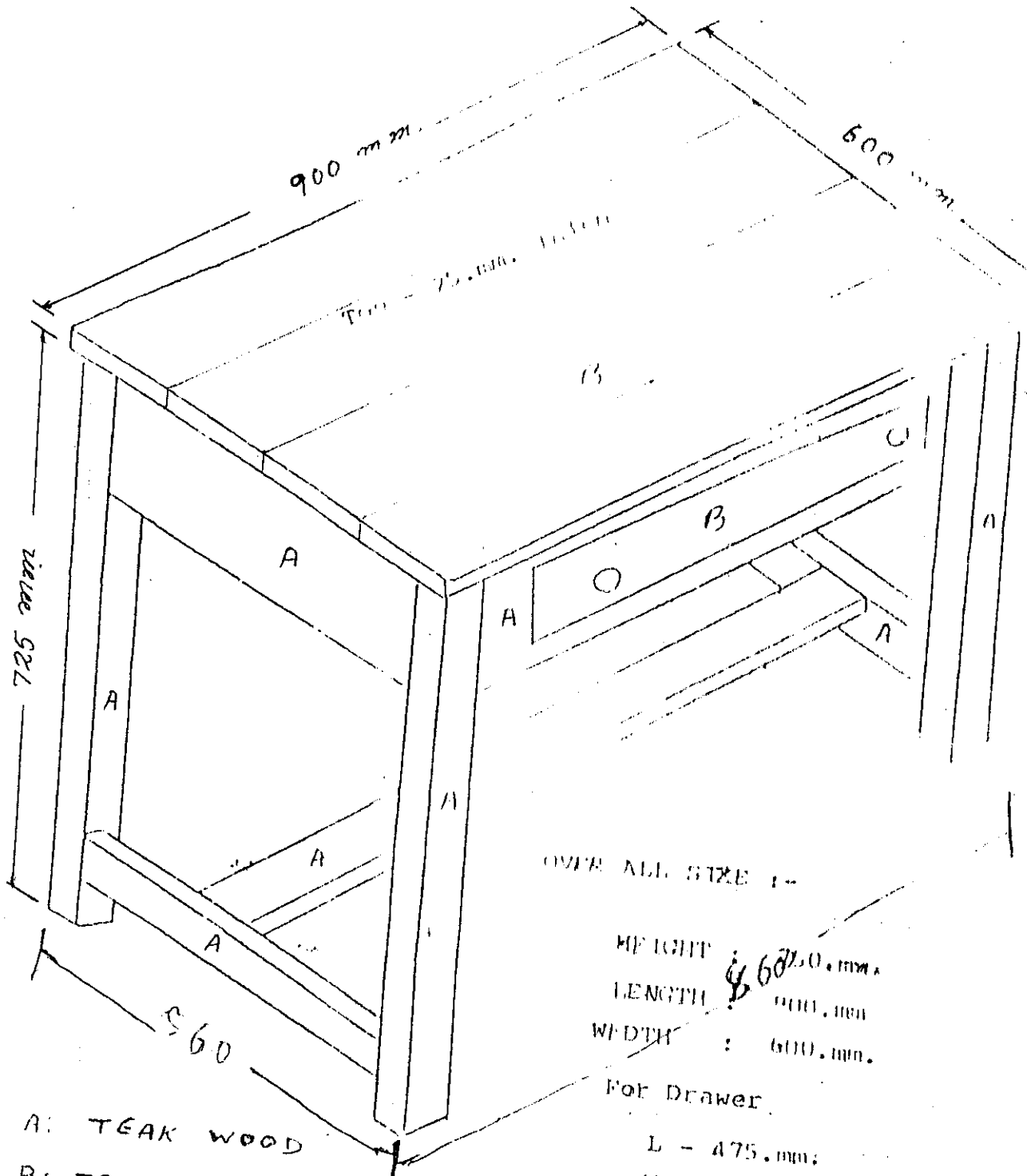

- A: TEAK WOOD
- B: TEAK WOOD.

For Drawer

- L - 475.000
- W - 600.000
- D - 100.000 with noke & locking arrangement.

- Leg 45 x 45 mm
- Support 46 x 35 mm

Education Officer
District Panchayat D&D
DIU

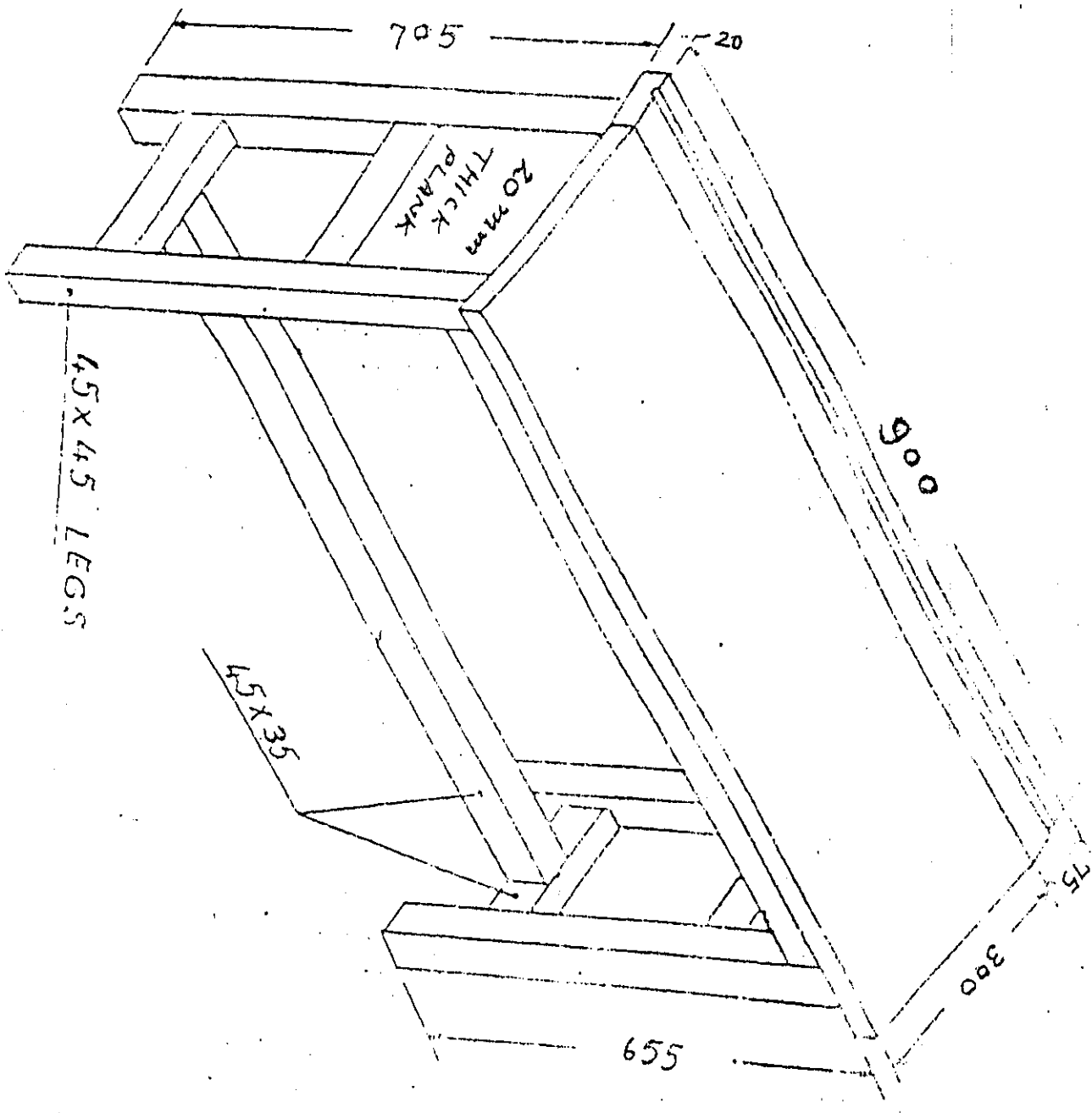
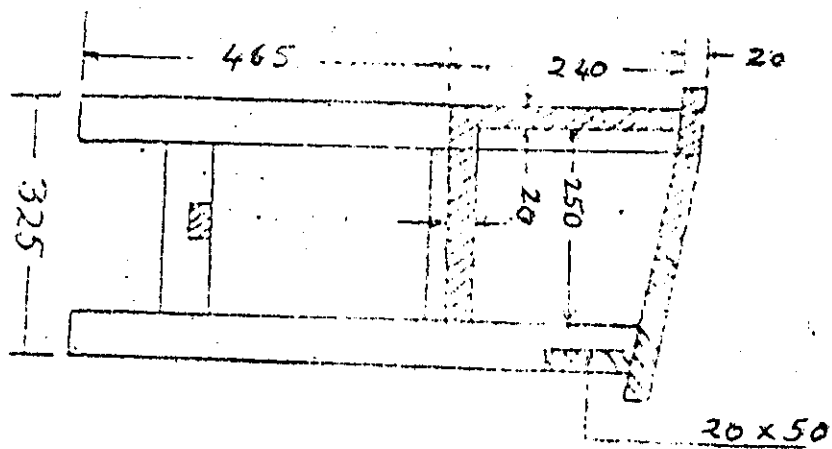

[TEAK WOOD]

WOODEN DESK

Measurement is shown in mm

Education Officer
District Panchayat D&D
D.P.